

# ROTAFLEX EFFICIENCY AND BALANCING

**J. N. McCoy, Echometer Company**  
**O. Lynn Rowlan, Amerada Hess**  
**Dr. A. L. Podio, University of Texas**  
**Dieter Becker, Echometer Company**

## Abstract

The RotaFlex pumping unit has a unique geometry that results in a constant torque arm (or torque factor) on most of the upstroke and downstroke. The geometry promotes high electrical efficiencies. Electrical efficiency can be measured by comparing the work required to raise the produced liquids from the net liquid level depth to the input electrical power. Also, electrical generation with the RotaFlex pumping unit is minimized compared to conventional beam pump units, which is favorable for high electrical efficiencies. RotaFlex balancing can be performed using electrical power measurements, and the amount of counterweight that must be added or removed from the counterweight box to balance the unit can be calculated directly by software using the power measurements and RotaFlex data. Power balancing does not require knowledge of the weight of the counterweight box and the auxiliary weights as is required with conventional mechanical balancing. An example of determining the electrical efficiency and of balancing a RotaFlex unit is given to further describe and explain the procedure for determining electrical efficiency and proper balance.

## Introduction

The RotaFlex is a long-stroke pumping unit that is mechanically driven. Generally, an electric motor drives a gearbox that in turn drives a long chain at a relatively constant speed. The chain travels around a lower sprocket that is fixed to the gearbox and also travels around an upper sprocket that is mounted at the top of a high mast. See Figures 1 and 2. The long stroke, 288 inches or more, is suited to larger pump capacities, and hence the RotaFlex is normally used on higher capacity wells. A weight box is attached to one of the links of the chain using a sliding linkage mechanism. The weight box moves with this chain link at a relatively constant speed on most of the upstroke and the downstroke. As the chain link travels around the upper sprocket and the lower sprocket, the link (as it comes in contact with the sprocket) begins to travel at a slower vertical speed until it reverses direction and gradually increases vertical speed until the link is again moving at a constant vertical velocity. While the chain always travels at a relatively constant velocity, a change in vertical velocity occurs in the chain link and the weight box at the top and the bottom of each stroke. The weight box is also attached to a long belt that runs over a drum at the top of the high mast and connects to a polished rod carrier bar that is located at the opposite end of the belt on the other side of the pulley.

## Characteristics of the RotaFlex Unit

The RotaFlex pumping system has a relatively constant speed on most of the upstroke and most of the downstroke. The linkage of the RotaFlex system results in a constant torque arm (or torque factor) on the

gearbox, which is equal to one-half of the pitch diameter of the driving sprocket that is attached to the gearbox during most of the stroke. The constant torque arm (or torque factor) and positive loads on most of the upstroke and downstroke (when the unit is balanced and the pump is full) result in work requirement by the motor during most of the upstroke and downstroke. At the very top and the bottom of the stroke, the moment arm becomes zero and the motor power requirement is low during these reversals.

The weight of the counterweight box including the auxiliary weights should equal approximately the buoyant weight of the rods plus one-half of the fluid load. Thus, energy must be supplied to the system during the polished rod upstroke because the weight of the rods plus the fluid load exceeds the weight of the weight box including the auxiliary weights. During the polished rod downstroke, the weight of the weight box exceeds the buoyant rod weight so power must be supplied to the system in order to raise the weight box while the rods are being lowered. For efficient operations, the pump should be completely filled with liquid so that the traveling valve will open at the top of the downstroke and remove the fluid load from the polished rod. Otherwise, at the beginning of the downstroke, the weight of the rods with the fluid load will exceed the weight of the weight box plus auxiliary weights and the system may actually drive the motor to a speed greater than its synchronous speed and into the generation phase that is inefficient. If the pump is not filled with liquid at the beginning of the downstroke when the unit runs continuously, the pumping unit should be put on 'P-0-C or time-clocked' so that the pumping unit will only operate when the pump is full to improve overall efficiency'. If a gaseous liquid column exists above the pump and the pump is not filled with liquid on the upstroke, the pump should be positioned below the formation, or a more efficient downhole gas separator should be utilized.

A conventional beam-pumping unit operates differently than the RotaFlex pumping system. In a beam pumping unit, the torque factor (or torque arm) is zero near the bottom and top of the stroke, and the torque factor increases approximately sinusoidally to maximum values near the middle of the upstroke and downstroke when the unit is reasonably balanced. The prime mover of a beam-pumping unit will generally slow down near the middle of the upstroke and downstroke, if reasonably balanced, and then speed up as the torque arm decreases near the top and bottom of the stroke. Generally, as the torque arm is reduced, the motor speeds **up**, and the motor is actually driven into generation at the top and the bottom of each stroke. Generation does supply electricity back to the power system, but electrical losses occur when a motor supplies excess potential and kinetic energy to a rotating system, and then, the excess potential and kinetic energy drives the motor and generates electricity<sup>3</sup>.

Motors are more efficient when operated near the rated output of the motor. Motors operating at light loads are relatively inefficient. If a pumping system is rod heavy, the motor will be relatively efficient when raising the rods if the motor is reasonably loaded. But, the motor will be inefficient when raising the counterweights if the motor is lightly loaded. When the pumping system is balanced so that the motor load on the upstroke is approximately equal to the motor load on the downstroke, the motor will be more heavily loaded a higher percentage of the time, and the overall electrical efficiency will improve<sup>4, 7</sup>. The reason that the RotaFlex pumping system is relatively efficient is that the motor is more uniformly loaded, and the motor is operating in a more efficient range a higher percentage of the time if the unit is properly balanced.

An example of the gearbox torque on a RotaFlex pumping unit is shown in the lower graph of Figure 5. The plot shows the torque at the output shaft of the gearbox as calculated from the instantaneous motor power measured during one complete pump stroke using the following equation:

$$\text{Torque} = 84.5 * \text{Power} * \text{EFF} / (\text{SPM} * \text{CR} * \text{SV}) \quad (\text{K inch-lbs})$$

Where:

Power= Instantaneous Motor Power (KW)

EFF=Motor to gearbox output shaft efficiency

SPM=pumping speed

CR=pumping speed to gearbox sprocket rotational speed ratio (chain ratio)

SV=Speed Variation, minimum speed / average speed

At the very beginning of the polished rod upstroke, the torque arm is near zero and the power requirement from the motor is very low. As the chain link that is attached to the weight box moves and leaves the idler sprocket, the torque arm becomes half of the pitch diameter (**16.8 inches**) and is constant throughout the remainder of the polished rod upstroke until the chain link comes in contact with the drive sprocket. Then, the vertical speed of the chain link slows to zero and reverses direction. When a reversal in the chain link and weight box direction occurs, the belt absorbs some of the change in load that occurs as the polished rod changes speed and direction. The load on the flexible belt and on the polished rod oscillates, and these load oscillations or “torque oscillations” affect the power requirements of the motor as shown in Figure 5. After the first portion of the upstroke, the oscillations tend to dampen and the load becomes more uniform. At the top of the upstroke, the polished rod reverses direction and travels downward. During the reversal and during the beginning of the downstroke, the load and torque again oscillate, but then dampen, and becomes more uniform.

### **RotaFlex Mechanical Torque Analysis and Balancing**

A mechanical method for determining the instantaneous torque throughout the pumping cycle is the mechanical torque factor method, which uses torque factors and polished-rod load and position data together with counterbalance weight.

The instantaneous gearbox torque at a given polished rod position (whether on the polished rod upstroke or downstroke) is the torque factor at that polished rod position multiplied by the net gearbox load at that position. During weight box ascent (polished rod downstroke), the net load on the gearbox is the weight of the counterweight box less the polished rod load. During the weight box descent (polished rod upstroke), the net gearbox load is the polished rod load minus the weight of the counterweight box. The net load can be positive or negative.

For RotaFlex pumping units, mechanical torque factors (TF) are normally calculated from the geometry of the particular RotaFlex pumping unit, and the torque factors are calculated relative to the position of the polished rod. Torque factors are positive (+) on both the upstroke and the downstroke. The torque factor is the same value at any polished rod position whether the unit is on the upstroke or downstroke.

For RotaFlex pumping units, the TF can be calculated at various polished rod positions from zero to a stroke length of **S** by the following equations:

$$\begin{aligned} \text{For } PR < R, & \quad TF = [R^2 - (R - PR)^2]^{1/2} \\ \text{For } PR > R \text{ and } PR < S - R, & \quad TF = R \\ \text{For } PR > S - R, & \quad TF = [R^2 - (R + PR - S)^2]^{1/2} \end{aligned}$$

Where:

- TF = Torque factor, inches
- R = Radius of the Driving Sprocket, inches
- S = Stroke Length, inches
- PR = Polished Rod Position, inches

The net load ( $W_n$ ) on the gearbox during weight box ascent (polished rod downstroke) is the weight of the counterweight box less the polished rod load, or

$$W_n = CB - W \text{ (weight box moving upward or polished rod downstroke)}$$

The net load ( $W_n$ ) on the gearbox during polished rod upstroke (counterweight box moving downward) is the polished rod load less the weight of the counterweight box, or

$$W_n = W - CB \text{ (polished rod upstroke or weight box moving downward)}$$

Where:

- $W_n$  = net load on the gearbox at a specific polished rod position (either upstroke or downstroke)
- CB = Weight of the counterweight box including auxiliary weights
- W = Load on the polished rod

Thus the net gearbox torque ( $T_{wn}$ ) at any polished rod position is equal to the torque factor at that polished rod position times the net load at that polished rod position, or

$$T_{wn} = TF * W_n$$

The Index of Torsional Effectiveness (ITE) is a factor that indicates the variance of the net gearbox torque throughout a cycle. ITE is the ratio of the average net torque to the peak torque, expressed as a percent. The ITE is a tool to compare different pumping units for the same or similar wells, with comparable production rates, pump intake pressures and pump depths. The higher the ITE, the more effective a particular pumping unit geometry is in converting the polished rod load into a more uniform torsional load. The following table compares various parameters for a RotaFlex, conventional and Mark II pumping units. For the same pump displacement, the RotaFlex has a better ITE than the Mark II or the

conventional pumping unit. The RotaFlex pumping unit has a more uniform gearbox torque load which results in a lower peak gearbox torque requirement and hence the use of a smaller gearbox.

PARAMETER	RotaFlex	Conventional	Mark II
Peak Polished Rod Load [PPRL]	26,495	27,522	25,329
Peak Torque [K in-lbs]	176.1	1128	974
Stroke Length [Inches]	288	192	216
Plunger Size [Inches]	2.25	2.25	2.25
Stroke per Minute	4.1	6.30	5.58
Rated Gearbox Size [K in-lbs]	320	1280	912
Pump Displacement [BPD]	640	640	640

## FIELD TEST

The RotaFlex equipped well that was tested is the Mallet Land & Cattle Co. No. 50. Chevron USA Inc operates the well. The RotaFlex unit is a model 1100 with a 306-inch stroke. The API designation is R-320-500-306. A 75 horsepower Nema D motor, Corods and a long stroke pump are utilized. The 2 inch pump is set below the formation, and the gas/liquid separation capacity of the 2-7/8" tubing on the inside of 5-1/2" casing exceeds the pump capacity of this high volume pump so that gas interference in the pump is not a problem. If liquid exists above the pump, the liquid is drawn into the pump on the upstroke.

A complete well analysis was performed to fully evaluate the well's performance<sup>6</sup>. An acoustic liquid level shot test is shown in Figure 3. The casing perforations are shown by the upward acoustic kicks at 16 to 16.5 seconds. The fluid level is below the casing perforations and is indicated on the acoustic chart as a downward kick at 16.514 seconds. Liquid is flowing from the lower casing perforations into the wellbore and falling to the pump. The casing pressure is low. The PBHP is 57.7 PSI. The low PBHP causes negligible resistance to the fluid flow from the high pressure (2000 PSI) formation into the wellbore. The maximum liquid inflow into the wellbore is obtained. The casing annulus gas flow rate is approximately 13 MCF per day. Two vibration anomalies are shown on the acoustic trace. One vibration anomaly is at 5.309 seconds and the second vibration anomaly is at 14.394 seconds. The anomalies (or vibrations) occur when the pumping unit reverses direction at the top and bottom of each stroke. These reversals vibrate the gas gun microphone and were noted when viewing the acoustic trace before the gas gun generated the acoustic pulse to determine liquid level depth. The pumping unit is running at 3.3 SPM, so these vibrations are about 9.09 seconds apart (60 SEC / 3.3 SPM / 2).

The dynamometer surface cards, pump card, traveling valve test and rod loadings are shown in Figure 4. Since the velocity of the polished rod on the upstroke and downstroke are relatively constant, the surface

card tends to exhibit a more rectangular shape than a conventional beam pump unit. The pump card shows that the pump is being filled with liquid.

The 2" pump and 2-7/8" seating nipple are set 52 feet below the bottom of the casing perforations. This allows the free gas from the formation to flow up the casing annulus and to separate from liquid that falls downward and enters the pump. The gas/liquid separation capacity' of the 2-7/8" tubing on the inside of 5-1/2" casing is approximately 635 *BID* which exceed the pump capacity of 423 B/D. Gas interference is not a problem even in this relatively high volume rod pumped well. This gas separation technique of setting the seating nipple below the producing interval results in efficient separation of free gas from liquid and improves pump efficiency when the gas/liquid separation capacity' of the tubing/casing combination exceeds the pump capacity.

A traveling valve test indicated that the pump leakage was approximately 4 BPD. The standing valve did not *leak*. The pump is operating properly.

Corods were installed in the well after problems occurred with the use of conventional rods. The Corods have not failed and are operating efficiently. The top Corod is 86% loaded at a service factor of 0.85.

Power measurements were obtained while the dynamometer data was acquired. Refer to Figure 5. A 75 horsepower motor Nema D is utilized. A 50 horsepower motor would operate this system, but the additional horsepower may be desired during certain well conditions. The overall system efficiency is 56.6%. That is, the amount of power required to raise the liquid produced by the well from the net liquid level depth is 56.6% of the power supplied to the motor. This is a relatively efficient pumping system.

The torque analysis is shown in the lower portion on the same Figure 5. The power or torque required on the upstroke is less than the power or torque required on the downstroke. Power can be converted to torque using the formula discussed earlier or shown in Figure 5. The measured upstroke peak torque was 119,100 inch-pounds, and the measured downstroke peak torque was 202,800 inch-pounds. Some of the weights in the counterweight box should be removed to reduce the counterbalance torque by 41,900 inch-pounds. This requires removing approximately 2,500 lbs. of auxiliary weight. The software calculates all these numbers from the power data and well database.

Balancing was undertaken in stages over a one-hour period as shown in the Table below. Initially, the unit was counterweight box heavy and more power and torque were required raising the weight box than the rods. The torque was more closely balanced after 782 lbs. of weights were removed from the weight box. After another 1,058 lbs. of weights were removed from the weight box, the pumping system was even closer balanced. The second and third dynamometer and power tests are not shown due to space limitations, but are available upon request. Finally, a total of an estimated 2760 lbs. of auxiliary weights were removed. The resulting power and torque data is shown in Figure 6. The unit is balanced after removal of the excess auxiliary weights. The peak gearbox torque was reduced from 202,800 inch-lbs. to 150,000 inch-lbs.

Time	Peak Upstroke Torque, Kin-lbs	Peak Downstroke Torque, Kin-lb	Calculated Balanced Torque, Kin-Lb	Weights to be Removed, Lbs	Weight removed, Lbs	Cumulative Weight removed, Lbs	Cumulative No. of weights removed	Counterbalance Effect Test, Lbs
12:30	119.1	202.8	161	2500	0	0	0	
13:02	135.9	180.5	158.2	1300	782	782	17	25132
13:19	134.51	162.2	148.4	8001	10581	1847	40	
13:29	147.21	150	148.6	100	9231	2760	60	

Figure 6 also shows the power and torque usage after the system was balanced. The average power consumption was decreased from 27.5 KW to 27 KW. The overall system efficiency increased from 56.6 to 57.5%, which is relatively efficient.

This technique of balancing the unit is based upon balancing the peak torque on the upstroke against the peak torque on the downstroke. The motor will be more efficient if the average power on the upstroke is balanced against the average power on the downstroke so that the motor will be operating overall at a higher efficiency. Motors operate more efficiently near rated output. The operator has the option of balancing the peak torques on the upstroke and downstroke, or balancing the average power usage on the upstroke and the downstroke. More efficient electrical operations will be obtained if average power is balanced rather than peak torques. However, the peak torques on the upstroke and downstroke should be balanced if the gearbox torque rating is exceeded when balancing by power usage.

The RotaFlex pumping system can also be balanced by using the mechanical loadings of the system rather than the electrical loadings on the motor. To balance the gearbox peak torque loadings by mechanical means, the polished rod loads and positions must be known as well as the weight of the counterbalance, which includes the weight box and auxiliary weights. In order to determine the weight of the weight box plus auxiliary weights, the counterbalance effect can be measured. On a RotaFlex, the geometry of the polished rod load and the Counterweight box is symmetrical, and the load measured by the horseshoe transducer is equal to the load in the belt that is attached to the counterweight box. If the pumping unit is stopped near the middle of the upstroke, the weight of the rods plus the fluid load will exceed the weight of the counterweight box plus auxiliary weights if the system is approximately balanced during normal operation. If the brake is held until some of the fluid load bleeds from the polished rod, the load on the polished rod will decrease. The brake can be momentarily released and reset, until a balanced condition occurs when the load on the polished rod is equal to the weight of the counterweight box. At this balanced condition, the belt will not move because the loads are equal. This weight can be measured accurately using the horseshoe transducer. If the brake is held longer, the load on the polished rod will continue to bleed off and the counterweight box and auxiliary weights will weigh more than the polished rod. Figure 8 shows the polished rod load while the system was pumping and then stopped on the

upstroke with the brake set. Periodically releasing then resetting the brake showed that at 46 seconds after data acquisition began, the belt did not move when the brake was released. The load at 46 seconds was 25.132 lbs. This polished rod load is equal to the weight of the counterweight box plus auxiliary weights. After the balanced condition was noted, the brake was reset, and the dynamometer test shows a further decline in the polished rod load.

The surface dynamometer cards and the pump cards after the unit is balanced are shown in Figure 7. The polished rod/motor efficiency increased slightly since the motor is operating in a more efficient range during the upstroke. The polished rod horsepower, the polished rod peak loadings and the polished rod minimum loadings remained similar as expected. Note that the efficiency between the pump power of 26.4 HP and the polished rod power of 29.4 HP is a high 90% which is probably due to the Corods having less metal-to-metal sliding friction and the Corods having less resistance to fluid flow from the pump to the surface up the tubing. A summary of measured values is presented in the following table.

Time	PPRL, Lbs	MPRL, Lbs	Motor Input Power, HP	Polished Rod Power, HP	Pump Power, HP	Polished Rod/Motor Efficiency, %	Pump/Motor Efficiency, %	Overall System Efficiency, %
12:30	32.200	13,700	36.8	29.7	26.7	80.8	72.5	56.6
13:02	32.100	13,900	36.9	29.7	26.6	80.5	72.2	56.6
13:19	32.000	14,200	36.5	29.5	26.5	80.7	72.4	57.1
13:29	32,000	14,200	36.2	29.4	26.4	81.1	72.8	57.5

## SUMMARY

After balancing, the RotaFlex system is efficiently producing all of the liquid available from the well. The RotaFlex is operated by P-0-C that pumps the well approximately 19.7 hours per day, which is all of the time required to remove all the liquids from the well bore. Before balancing, the pumping unit was counterweight box heavy and excessive power usage and excessive gearbox loading were experienced. The unit was balanced and the maximum gearbox loading was reduced from 202,800 inch-pounds to 150,000 inch-pounds. The average power requirement was reduced from 27.5 KW to 27 KW. The system efficiency, when balanced, was 57.5%, which is relatively good. The cost of electricity was reduced approximately \$14 per month.



References: (Papers are available from [www.echometer.com](http://www.echometer.com) and [info@echometer.com](mailto:info@echometer.com))

1. Lea, J.F., Lynn Rowlan and Jim McCoy: "Artificial Lift Power Efficiency," Southwestern Petroleum Short Course, Texas Tech University, Lubbock, Texas. April 1999.
2. McCoy, J.N., Dieter Becker and A.L. Podio: "Timer Control of Beam Pump Run Time Reduces Operating Expense," Southwestern Petroleum Short Course, Texas Tech University, Lubbock, Texas, April 1999.
3. McCoy, J.N., A.L. Podio, Russ Ott and Mike Woods: "Electrical Motor Power Measurement as the Key for Optimized Rod Pumping," SPE 36080, SPE, Richardson, Texas, April 1996.
4. McCoy, J.N., Forrest Collier and A.L. Podio: "Application of Real-Time Measurement of Motor Power to Determination of Beam Pump Efficiency," Southwestern Petroleum Short Course, Texas Tech University, Lubbock, Texas, April 1995.
5. Lea, J.F. and J.D. Minissale: "Beam Pumps Surpass ESP Efficiency," *Oil and Gas Journal*, May 18, 1992, pp. 72-75.
6. Podio, A.L., J.N. McCoy, B. Drake and D. Becker: "Total Well Management-A Methodology for Minimizing Production Cost of Beam Pumped Wells", The Petroleum Society of CIM, Paper 95-26, May, 1995.
7. Ott, Russ et al.: "Reducing Electrical Consumption of Beam Pumping Units by Properly Counterbalancing Using PC Software," Southwestern Petroleum Short Course, Texas Tech University, Lubbock, Texas, April 1995.
8. McCoy, J.N. and A.L. Podio: "Improved Downhole Gas Separators," Southwestern Petroleum Short Course, Texas Tech University, Lubbock, Texas, April 1998.

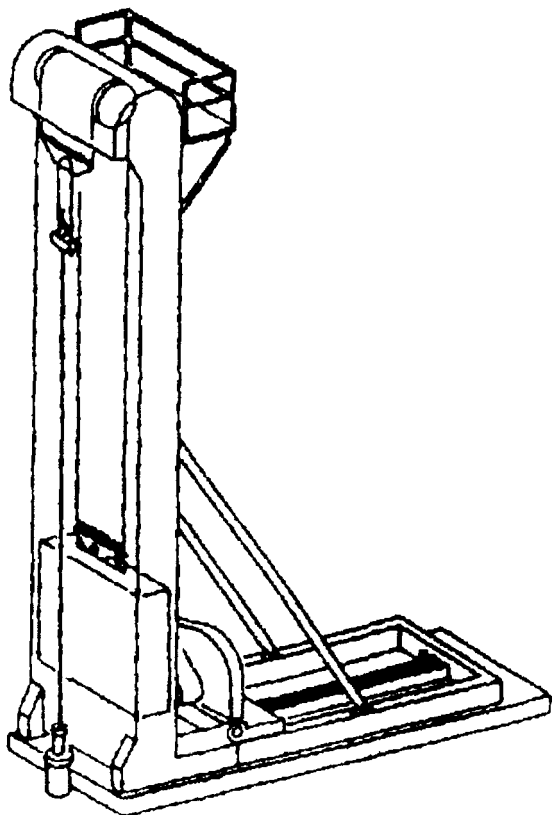

Figure 1 - RotaFlex Unit

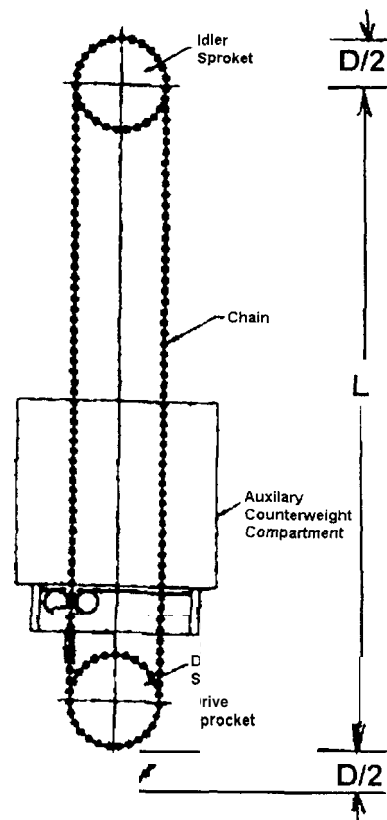
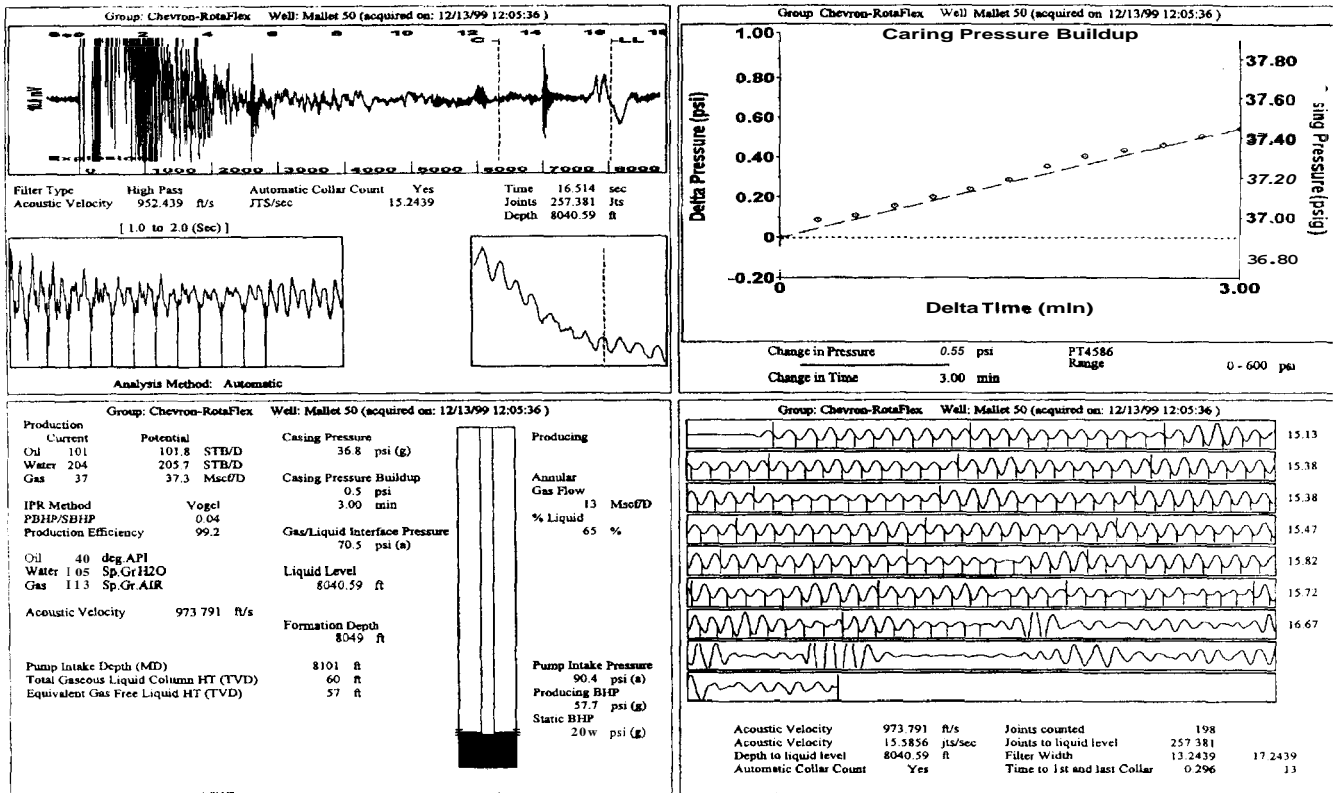
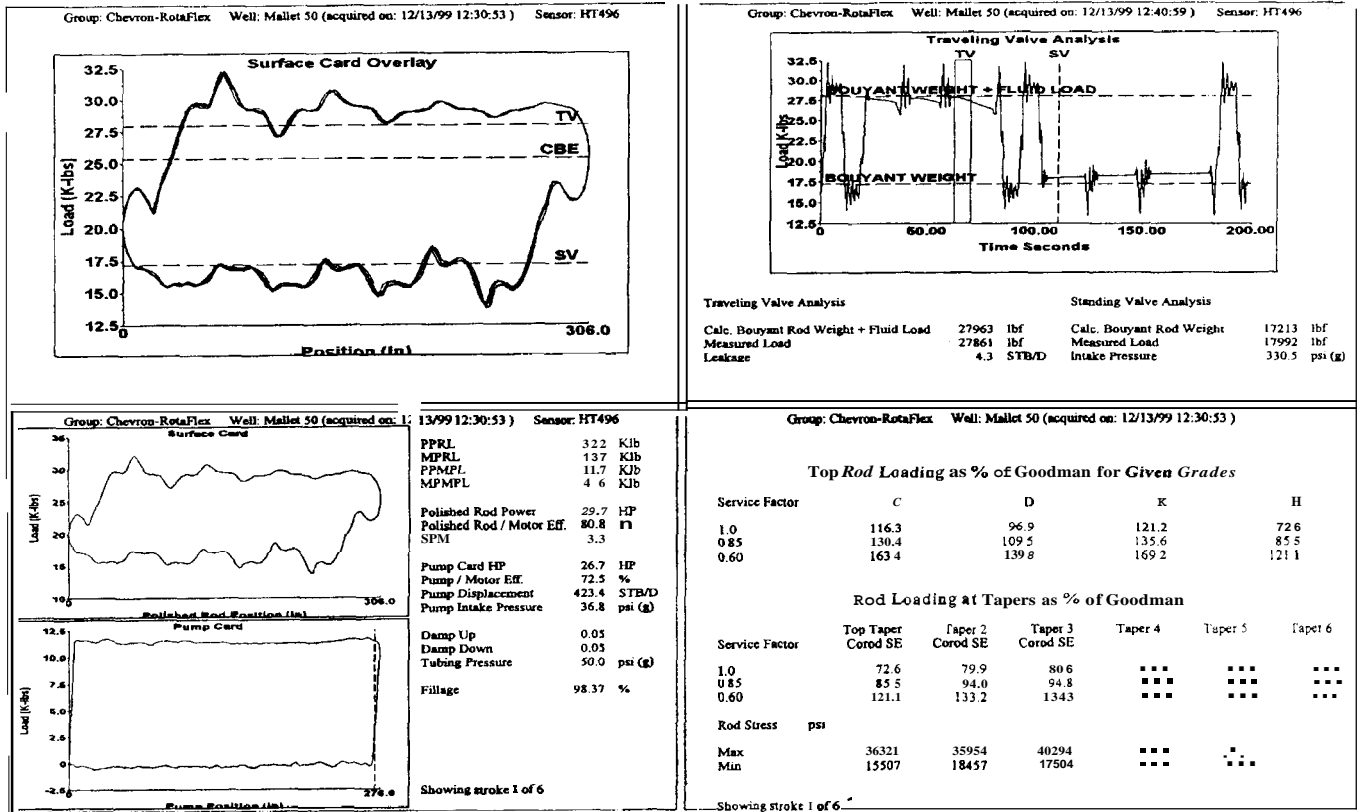

Figure 2 - RotaFlex Chain Drive



TOTAL WELL MANAGEMENT by ECHOMETER Company 01/26/00 14:41:35

Figure 3



TOTAL WELL MANAGEMENT by ECHOMETER Company 01/26/00 15:32:42

Figure 4

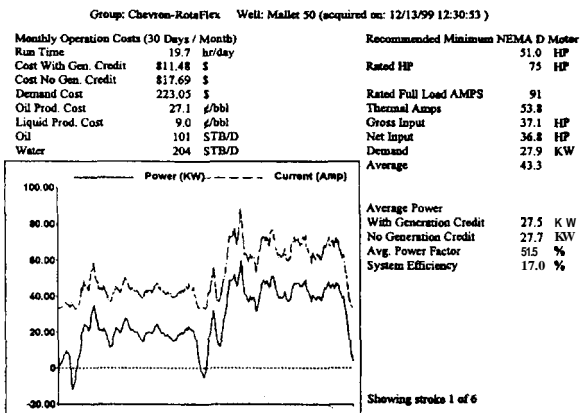

Figure 5

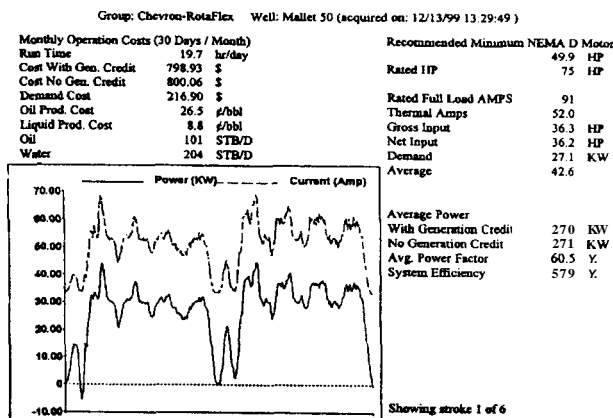
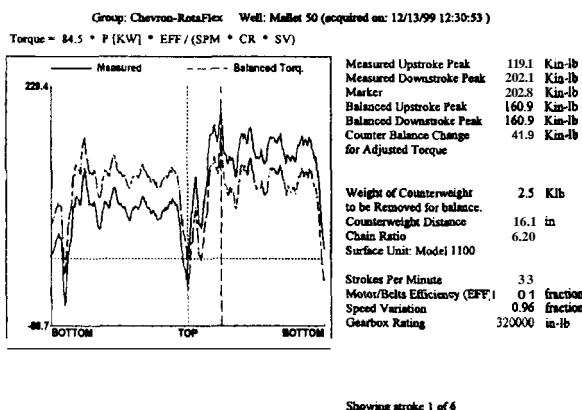
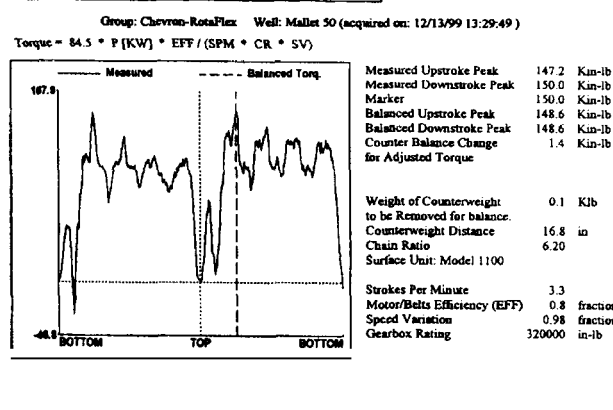

Figure 6



Showing stroke 1 of 6



Showing stroke 1 of 6

Group: Chevron-RotaFlex Well: Mallet 50 (acquired on: 12/13/99 13:29:49) Sensor: HT496

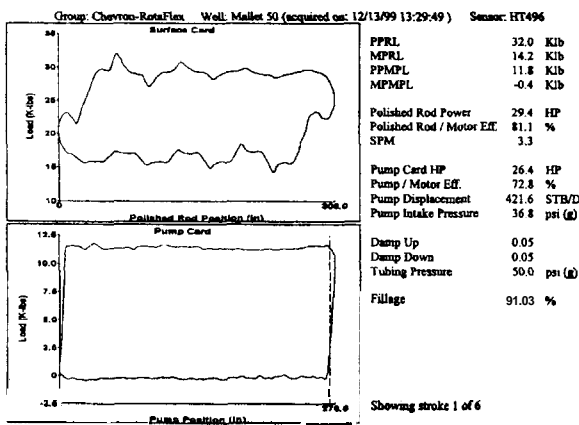
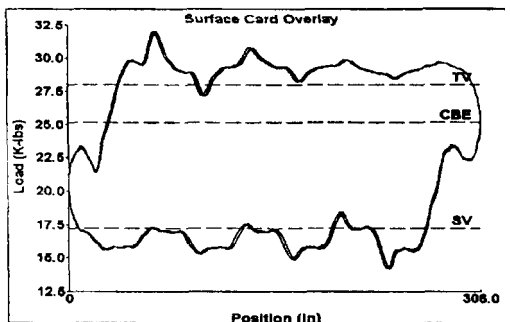

TOTALWELL MANAGEMENT by ECHOME R Company 01/27/00 15:46

Figure 7

Group: Chevron-RotaFlex Well: Mallet 50 (acquired on: 12/13/99 13:08:24)

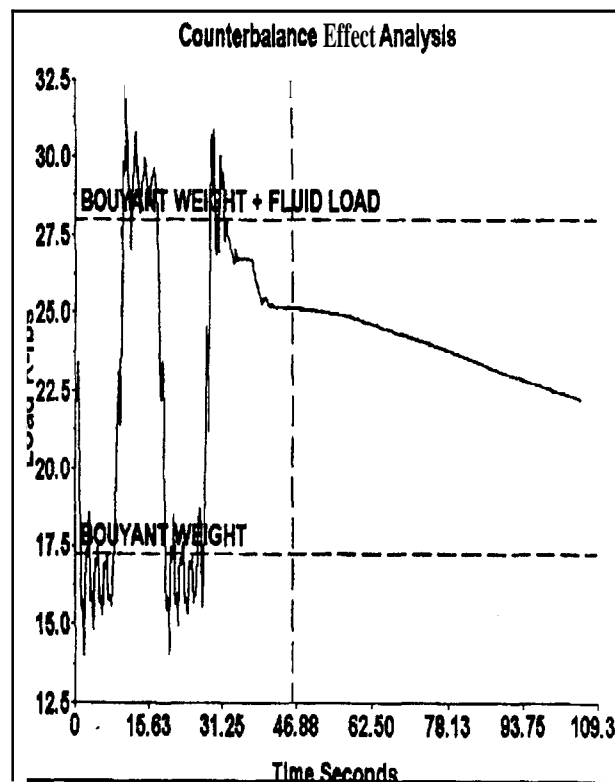

Figure 8